

1	Type	Wide Angle Lens	
2	Resolution	MP	
3	Image Format	1/2.9"	
4	Image Circle	φ6.8mm(MAX)	
5	EFL	2.18mm	
6	TTL	14.50mm	
7	F/NO.	F2.4	
8	FFL (M)	2.7mm	
9	BFL (O)	3.65mm	
10	For Sensor	GC2093	
11	F.O.V	Horizontal	140.7°
12		Vertical	78.4°
13		Diagonal	166.3°
14	TV Distortion	<-28%	
15	Relative Ill.	>50%	
16	Chief Ray Angle	<16°	
17	M.O.D	0.1m~∞	
18	Mount Type	M12*P0.5	
19	Dimension Figure	φ14.0*L11.80mm	
20	Lens Structure	2G3P	
21	IR-Filter	Non-IR	
22	Waterproof	No	
23	Weight	2.4g	
24	Iris Operation	Fixed	
25	Zoom Operation	Fixed	
26	Focus Operation	Manual	
27	Operating Temperature	-25° ~+85°	
28	Storage Temperature	-25° ~+85°	

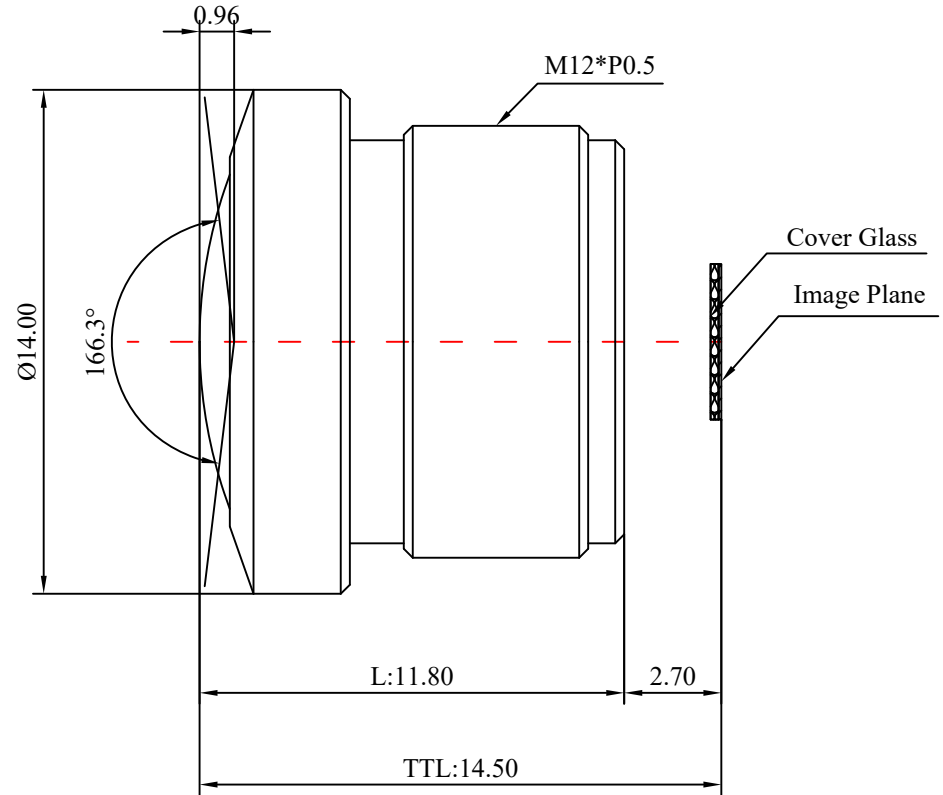

Scale	Remark	Tolerances	Date	Revised	
4:1	X	±0.2	2024-04-06	CH8101A Rev1.0	
	X.0	±0.15			
Units	X.00	±0.10	Design	Linda	2024-03-03
	X.000	±0.001	Checked	Anna	2024-03-12
mm	Angle	±0.5°	Approval	Sanmu	2024-04-03

福州创安光电科技有限公司  
FUZHOU CHUANGAN OPTICS CO., LTD

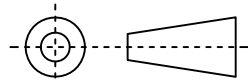

3D Angle Projection