

1	Type	Wide Angle Lens	
2	Resolution	50MP	
3	Image Format	1/1.55"	
4	Image Circle	φ11.0mm(MAX)	
5	EFL	4.11mm	
6	TTL	27.00mm	
7	F/NO.	2.0	
8	FFL (M)	3.10mm	
9	BFL (O)	3.90mm	
10	For Sensor	OV50E40	
11	F.O.V	Horizontal	102.8°
12		Vertical	78.3°
13		Diagonal	130°
14	TV Distortion	<10.14%	
15	Relative Ill.	>64.5%	
16	Chief Ray Angle	<15.62°	
17	M.O.D	0.1m~∞	
18	Mount Type	M12*P0.5	
19	Dimension Figure	φ22.0*L23.90mm	
20	Lens Structure	4G4P	
21	IR-Filter	Non-IR	
22	Waterproof	No	
23	Weight	---	
24	Iris Operation	Fixed	
25	Zoom Operation	Fixed	
26	Focus Operation	Manual	
27	Operating Temperature	-45° ~+85°	
28	Storage Temperature	-45° ~+85°	

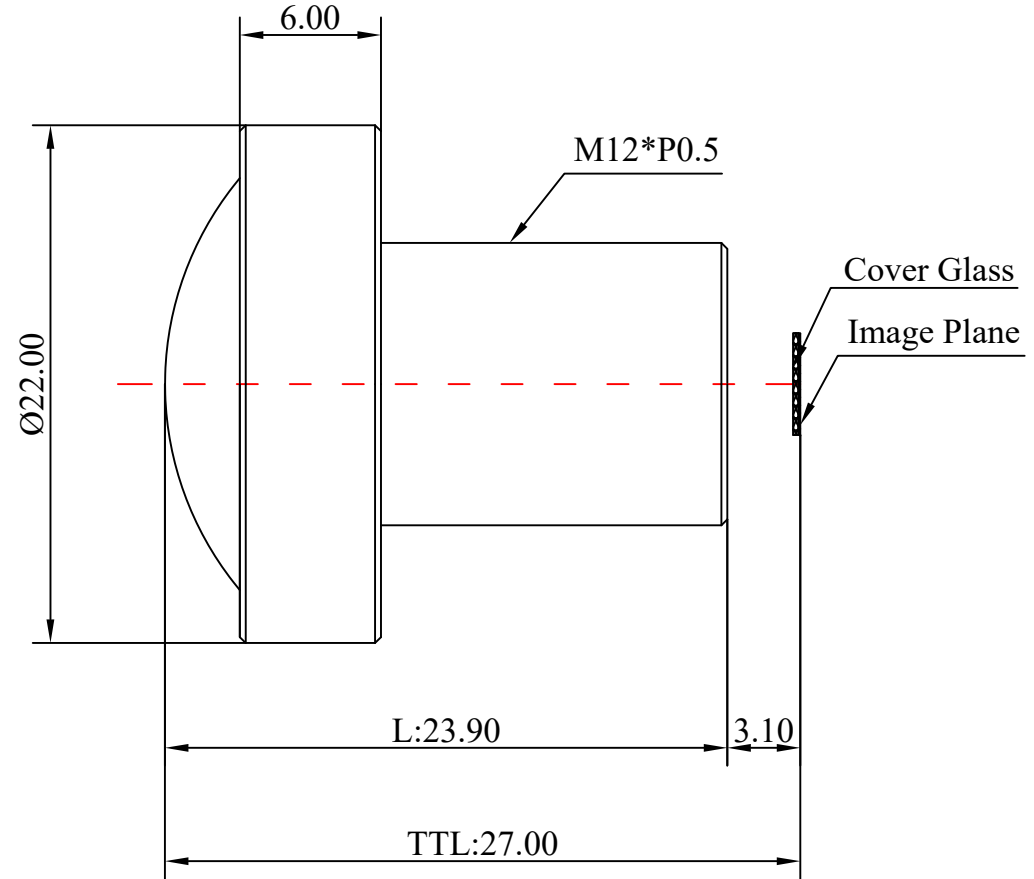
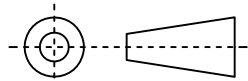

Scale	Remark	Tolerances	Date	Revised		福州创安光电科技有限公司 FUZHOU CHUANGAN OPTICS CO., LTD
4:1	X	±0.2	2024-04-16	CH8090A Rev1.0		
Units	X.0	±0.15				 3D Angle Projection
	X.000	±0.001	Design	Linda	2024-04-03	
mm	Angle	±0.5°	Checked	Anna	2024-04-08	
			Approval	Sanmu	2024-04-12	