

EFL		75mm	
F/No.		F2.8-16	
Resolution		10MP	
For Sensor		2/3"(8.8x6.6mm)	
F.O.V	H	6.71°	
	V	5.04°	
	D	8.38°	
Object Dimension at 150mm	H	40.11mm	
	V	30.09mm	
	D	50.12mm	
TV Distortion		<-0.2%	
M.O.D		0.4m~∞	
FFL		17.526mm	
BFL		43.68mm	
Filter Size		M30.5*0.5	
Front/ Rear Effective Dia		Ø30mm/Ø17mm	
Mount Type		C-Mount	
Operating Temperature		-20°C~+85°C	
Storage Temperature		-20°C~+85°C	
Working Distance(mm)	Optical Magnificationi	2/3" F.O.V (mm) H*V	
3000	0.0255X	344.5	258.5
1500	0.0521X	168.73	126.61
1200	0.0659X	133.53	100.19
1000	0.0799X	110.10	82.61
850	0.0951X	92.55	69.43
700	0.1173X	75.04	56.29
600	0.1389X	63.36	47.53
500	0.1702X	51.72	38.8
450	0.1918X	45.91	34.44
400	0.2195X	40.11	30.09

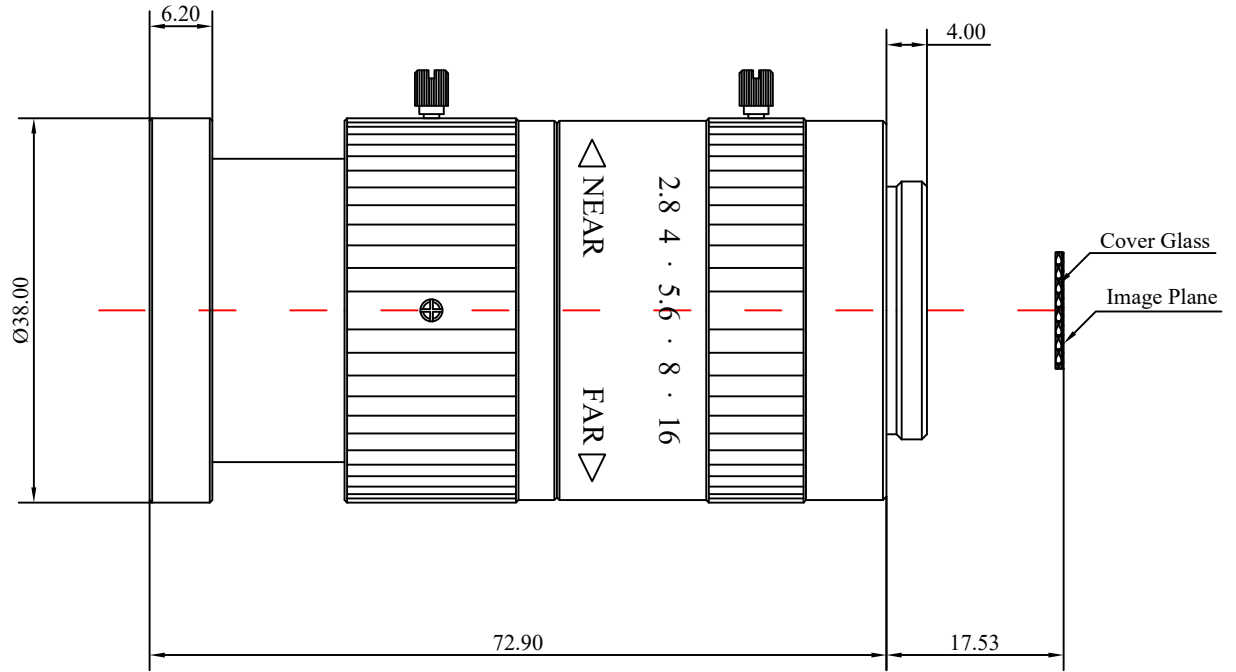
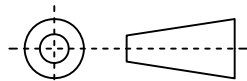

Scale	Remark	Tolerances	Date	Revised		福州创安光电科技有限公司 FUZHOU CHUANGAN OPTICS CO., LTD
4:1	X	±0.2	2024-04-07	CH684A Rev1.0		 3D Angle Projection
	X.0	±0.15				
Units	X.00	±0.10	Design	Linda	2024-01-02	
	X.000	±0.001	Checked	Anna	2024-02-01	
mm	Angle	±0.5°	Approval	Sanmu	2024-03-18	