

EFL		35mm	
F/No.		F2.8-16	
Resolution		10MP	
For Sensor		2/3" (8.8x6.6mm)	1/2" (6.4x4.8mm)
F.O.V	H	13.1°	9.5°
	V	9.9°	7.2°
	D	16.3°	11.9°
Object Dimension at 150mm	H	50.7mm	36.8mm
	V	38mm	27.6mm
	D	63.2mm	46mm
TV Distortion		<-0.1%	<0.05%
M.O.D		0.1m~∞	
FFL		17.526mm	
BFL		16.55mm	
Filter Size		M27*0.5	
Front/ Rear Effective Dia		Ø16.8mm/Ø11mm	
Mount Type		C-Mount	
Operating Temperature		-20°C~+85°C	
Storage Temperature		-20°C~+85°C	
Working Distance(mm)	Optical Magnification	2/3" F.O.V (mm)	
5000	0.017X	1253	940
2000	0.018X	501.6	376.2
1000	0.035X	251.1	188.4
900	0.039X	226.1	169.6
800	0.044X	201	150.8
700	0.05X	176	132
600	0.058X	150.9	113.2
550	0.064X	138.4	103.8
500	0.07X	125.9	94.4
450	0.078X	113.4	85
400	0.087X	100.8	75.6
350	0.1X	88.3	66.2
300	0.116X	75.8	56.8
250	0.139X	63.2	47.4
200	0.174X	50.7	38
150	0.231X	38.1	28.6
100	0.347X	25.5	19.2

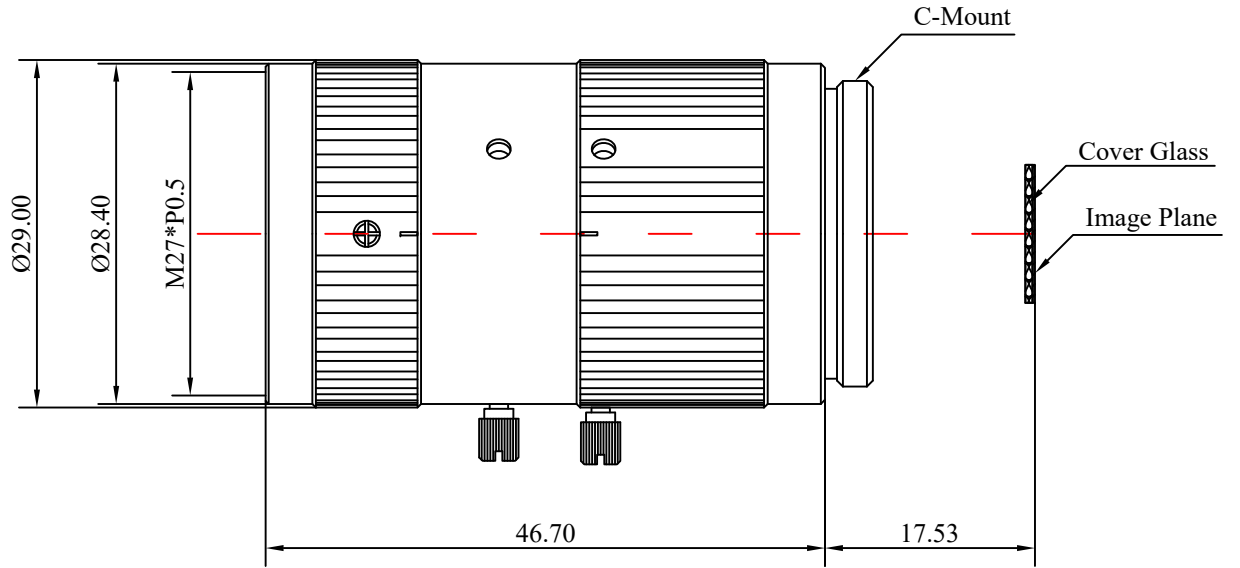
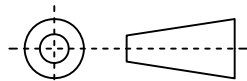

Scale	Remark	Tolerances	Date	Revised		福州创安光电科技有限公司 FUZHOU CHUANGAN OPTICS CO., LTD
4:1	X	±0.2	2024-04-07	CH682A Rev1.0		 3D Angle Projection
	X.0	±0.15				
Units	X.00	±0.10	Design	Linda	2024-01-02	
	X.000	±0.001	Checked	Anna	2024-02-01	
mm	Angle	±0.5°	Approval	Sanmu	2024-03-18	