

1	Type	Machine vision Lens	
2	EFL	75mm	
3	F.NO	F2.8	
4	Resolution	10MP	
5	Image Format	1"	
6	BFL (M)	---	
7	For Sensor	1"	2/3"
8	F.O.V	Horizontal	9.8°
9		Vertical	7.4°
10		Diagonal	12.2°
11	TV Distortion	<-0.05%	<-0.03%
12	M.O.D	0.1m	
13	Mount Type	1-32 UNF	
14	Dimension Figure	φ40.0*L50mm	
15	Filter Size	M37*0.75	
16	Weight	118g	
17	Iris Operation	Fixed	
18	Zoom Operation	Fixed	
19	Focus Operation	Manual	
20	Operating Temperature	-20° +85°	
21	Storage Temperature	-20° +85°	

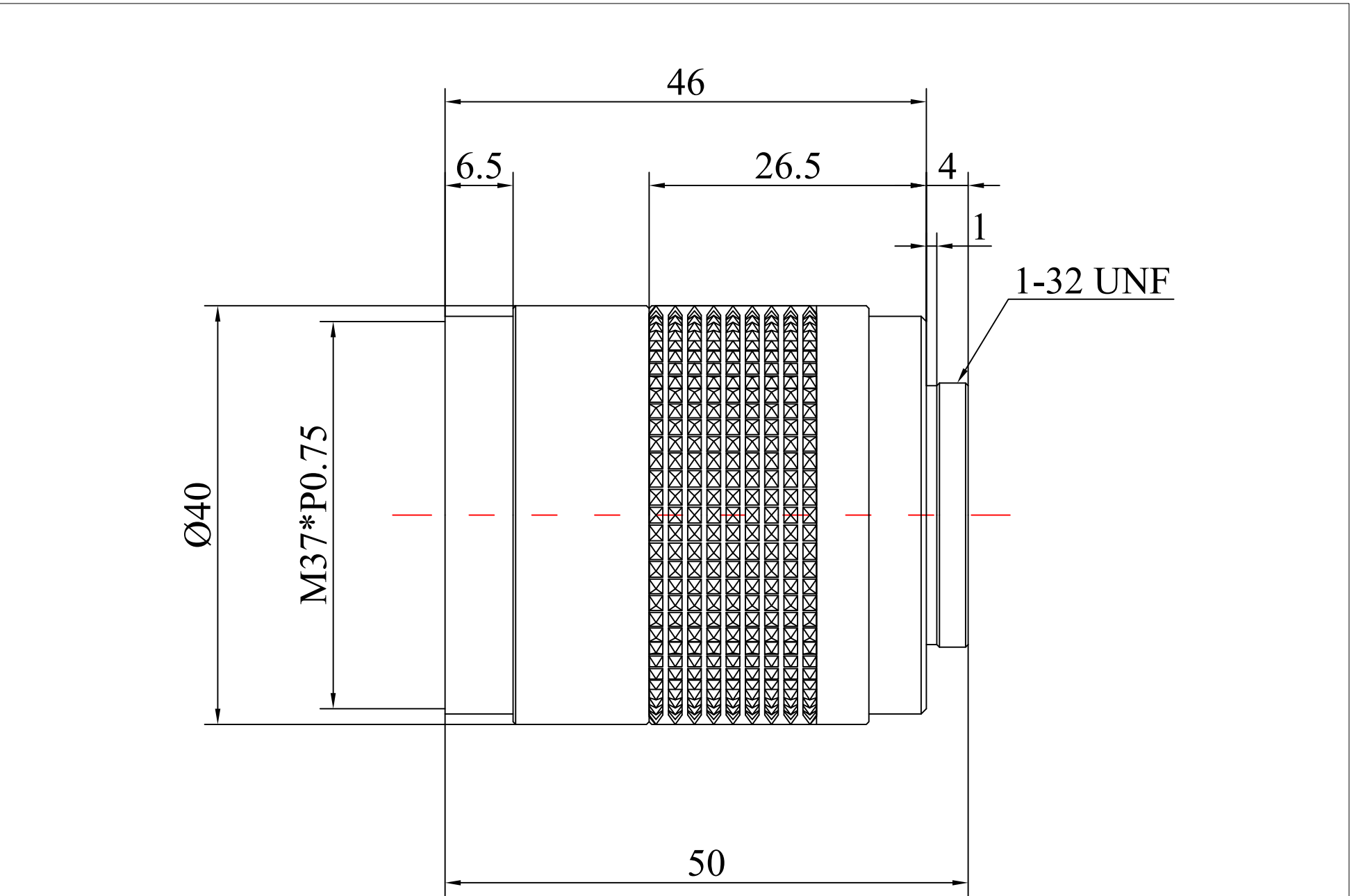
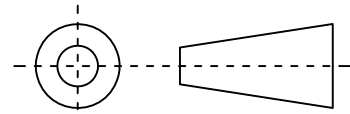

Remark: 聚焦内调, 后焦补偿7mm

Scale	Remark	Tolerances	Date	Revised		福州创安光电科技有限公司 FUZHOU CHUANGAN OPTICS CO., LTD
1.5 : 1	X	±0.2	2022-05-26	CH614D Rev1.0		
	X.0	±0.15				
Units	X.00	±0.10	Design	Linda	2016-02-10	 3D Angle Projection
	X.000	±0.001	Checked	Anna	2016-05-07	
mm	Angle	±0.5°	Approval	Sanmu	2016-05-28	