

1	Type	M12 Lens	
2	Resolution	5MP	
3	Image Format	1/2.8"	
4	Image Circle	φ6.3mm(MAX)	
5	EFL	2.4mm	
6	TTL	17.67mm	
7	F/NO.	1.8	
8	FFL (M)	2.77mm	
9	BFL (O)	3.65mm	
10	For Sensor	IMX335 (2560*1440 2.0um)	
11	F.O.V	Horizontal	134° @5.12mm
12		Vertical	70° @2.88mm
13		Diagonal	160° @5.874mm
14	OPT Distortion	<-78.7% @5.874mm	
15	Relative Ill.	>59% @5.874mm	
16	Chief Ray Angle	<14° @5.874mm	
17	M.O.D	0.1m~∞	
18	Mount Type	M12*P0.5	
19	Dimension Figure	φ14.00*L14.90mm	
20	Lens Structure	6G	
21	IR-Filter	Non-IR	
22	Waterproof	No	
23	Weight	6G	
24	Iris Operation	Fixed	
25	Zoom Operation	Fixed	
26	Focus Operation	Manual	
27	Operating Temperature	-20° ~+85°	
28	Storage Temperature	-20° ~+85°	

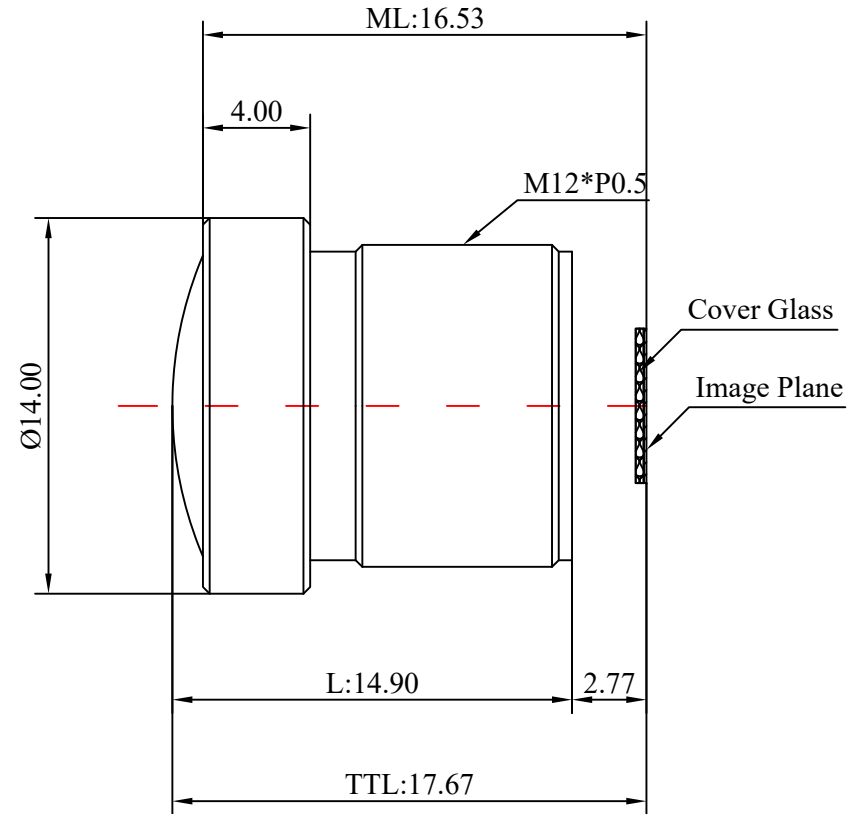
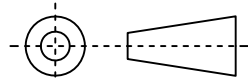

Scale	Remark	Tolerances	Date	Revised		福州创安光电科技有限公司 FUZHOU CHUANGAN OPTICS CO., LTD
4:1	X	±0.2	2023-05-05	CH3840A Rev1.0		
Units	X.00	±0.10	Design	Linda	2023-03-23	 3D Angle Projection
	X.000	±0.001	Checked	Anna	2023-04-06	
mm	Angle	±0.5°	Approval	Sanmu	2023-04-29	