

1	Type	Wide Angle Lens		
2	Resolution	MP		
3	Image Format	1/2.8"		
4	Image Circle	φ6.8mm(MAX)		
5	EFL	2.8mm		
6	TTL	22.50mm		
7	F/NO.	1.8		
8	FFL (M)	4.48mm		
9	BFL (O)	5.02mm		
10	For Sensor	IMX415	IMX335	
11	F.O.V	Horizontal	124°	114°
12		Vertical	64°	81°
13		Diagonal	148°	150°
14	OPT Distortion	<-72%		
15	Relative Ill.	>58%		
16	Chief Ray Angle	<13°		
17	M.O.D	0.1m~∞		
18	Mount Type	M12*P0.5		
19	Dimension Figure	φ17.00*L18.02mm		
20	Lens Structure	6G		
21	IR-Filter	T=50% & 650±10nm		
22	Waterproof	IP67		
23	Weight	6.3g		
24	Iris Operation	Fixed		
25	Zoom Operation	Fixed		
26	Focus Operation	Manual		
27	Operating Temperature	-20° ~+85°		
28	Storage Temperature	-20° ~+85°		

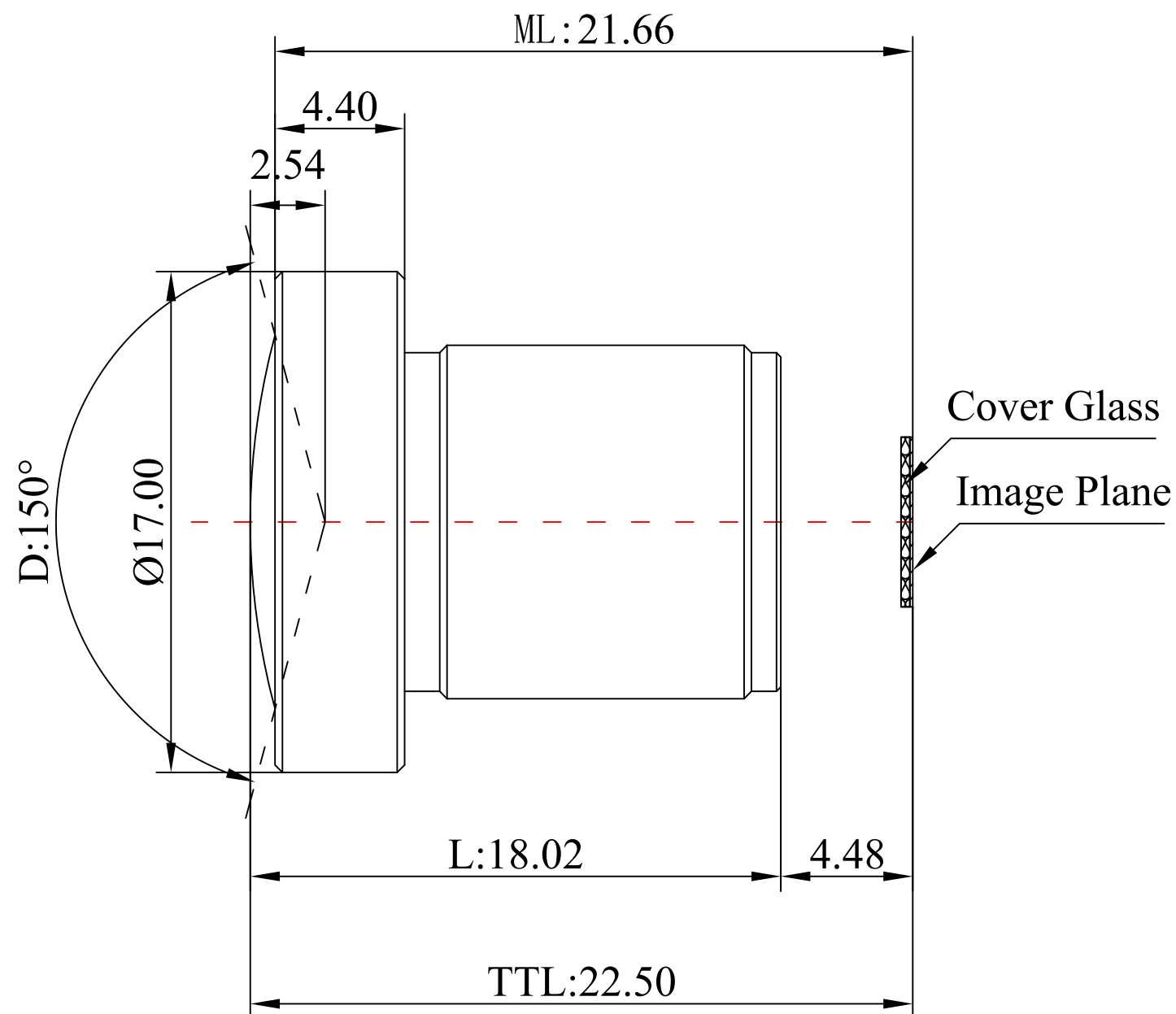
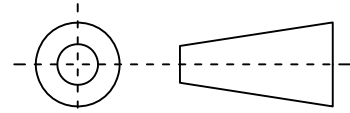

Scale	Remark	Tolerances	Date	Revised		福州创安光电科技有限公司 FUZHOU CHUANGAN OPTICS CO., LTD
4:1	X	±0.2	2019-07-22	CH3648A Rev1.0		
	X.0	±0.15				
Units	X.00	±0.10	Design	Linda	2016-05-26	 3D Angle Projection
	X.000	±0.001	Checked	Anna	2016-07-20	
mm	Angle	±0.5°	Approval	Sanmu	2016-07-20	