

1	Type	Wide Angle Lens		
2	Resolution	MP		
3	Image Format	1/3.6"		
4	Image Circle	φ5.1mm(MAX)		
5	EFL	2.75mm		
6	TTL	12.21mm		
7	F/NO.	2.4		
8	FFL (M)	2.92mm		
9	BFL (O)	3.05mm		
10	For Sensor	1/3.6"	1/4"	
11	F.O.V	Horizontal	90.3°	79°
12		Vertical	64.4°	57.7°
13		Diagonal	121.4°	103.2°
14	TV Distortion	<-25%		
15	Relative Ill.	>59.8%		
16	Chief Ray Angle	<24°		
17	M.O.D	0.1m~∞		
18	Mount Type	M8*P0.35		
19	Dimension Figure	φ11.0*L9.29mm		
20	Lens Structure	5G		
21	IR-Filter	T=50% &650±10nm		
22	Waterproof	No		
23	Weight	---		
24	Iris Operation	Fixed		
25	Zoom Operation	Fixed		
26	Focus Operation	Manual		
27	Operating Temperature	-20° ~+85°		
28	Storage Temperature	-20° ~+85°		

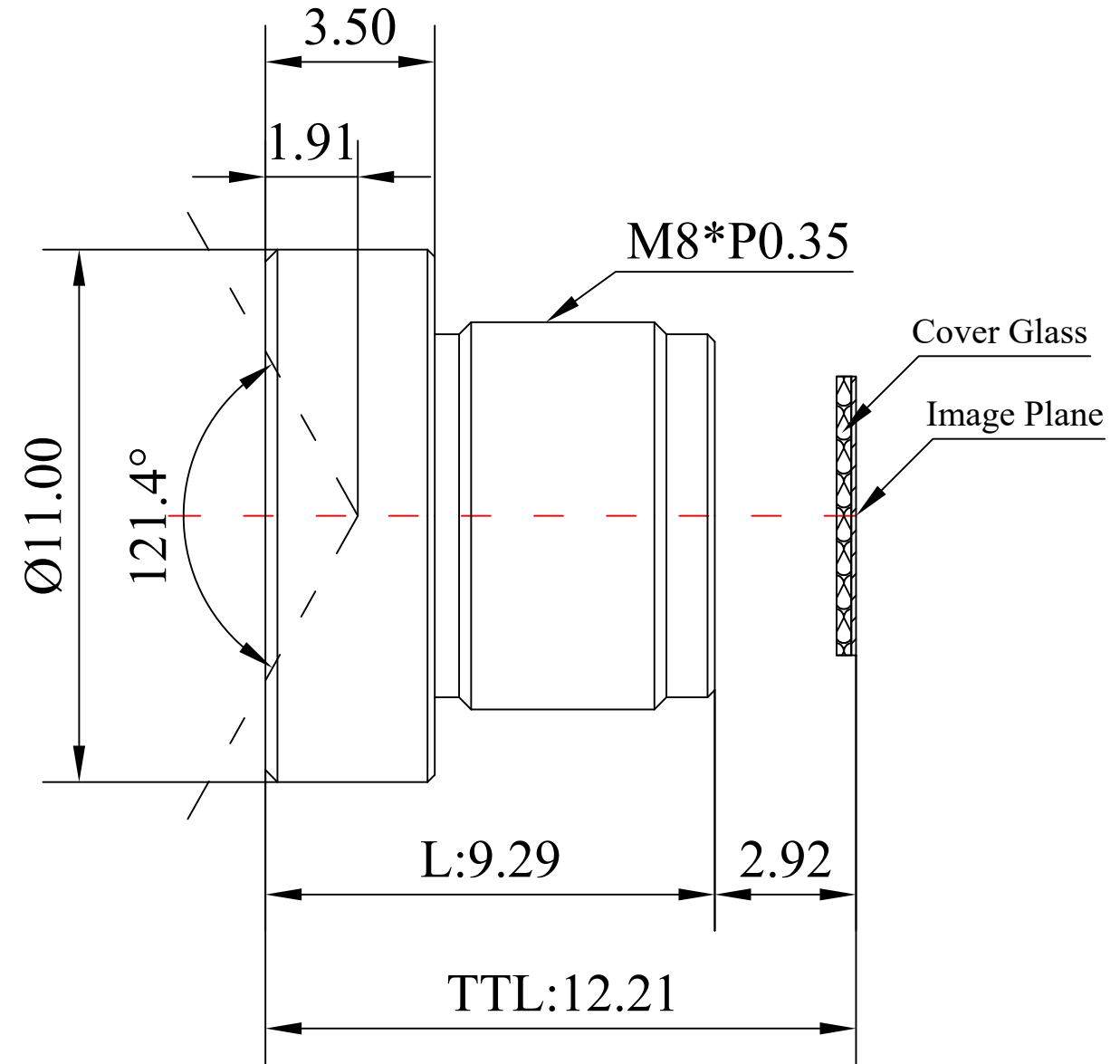
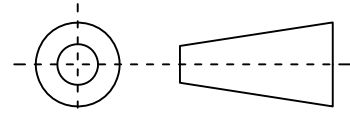

Scale	Remark	Tolerances	Date	Revised		福州创安光电科技有限公司 FUZHOU CHUANGAN OPTICS CO., LTD
5:1	X	±0.2	2020-03-10	CH3634A Rev1.0		
	X.0	±0.15				
Units	X.00	±0.10	Design	Linda	2019-03-13	 3D Angle Projection
	X.000	±0.001	Checked	Anna	2019-06-26	
mm	Angle	±0.5°	Approval	Sanmu	2019-06-29	