

1	Type	Wide Angle Lens	
2	Resolution	MP	
3	Image Format	1/3"	
4	Image Circle	φ6.7mm(MAX)	
5	EFL	2.28mm	
6	TTL	17.42mm	
7	F/NO.	2.0	
8	FFL (M)	3.52mm	
9	BFL (O)	3.76mm	
10	For Sensor	1/3"	
11	F.O.V	Horizontal	138°
12		Vertical	72°
13		Diagonal	170°
14	TV Distortion	<-25%(H)	
15	Relative Ill.	>70%	
16	Chief Ray Angle	<12.5°	
17	M.O.D	0.1m~∞	
18	Mount Type	M12*P0.5	
19	Dimension Figure	φ14.00*L13.90mm	
20	Lens Structure	6G	
21	IR-Filter	Non-IR	
22	Waterproof	No	
23	Weight	4.8g	
24	Iris Operation	Fixed	
25	Zoom Operation	Fixed	
26	Focus Operation	Manual	
27	Operating Temperature	-20° ~+85°	
28	Storage Temperature	-20° ~+85°	

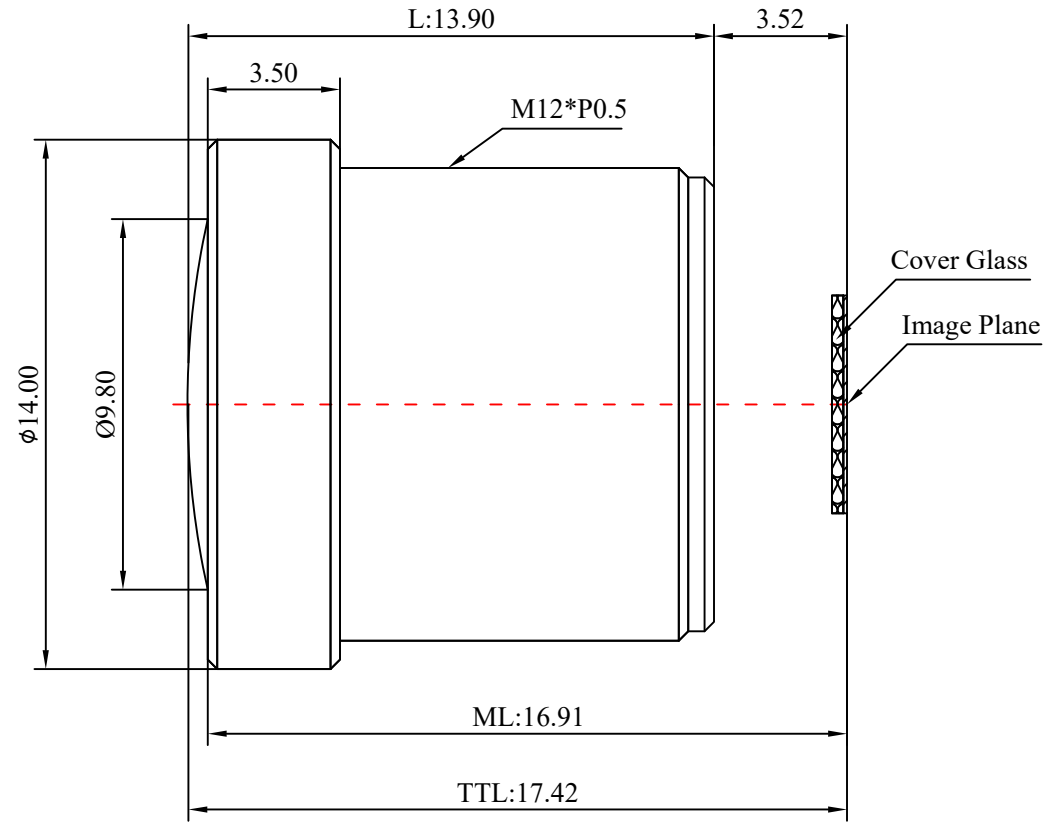
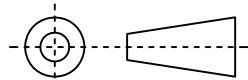

Scale	Remark	Tolerances	Date	Revised		福州创安光电科技有限公司 FUZHOU CHUANGAN OPTICS CO., LTD
5 : 1	X	±0.2	2019-06-20	CH362A Rev1.0		
	X.0	±0.15				
Units	X.00	±0.10	Design	Linda	2014-12-26	 3D Angle Projection
	X.000	±0.001	Checked	Anna	2015-03-09	
mm	Angle	±0.5°	Approval	Sanmu	2015-03-11	