

1	Type	C-Fisheye lens	
2	Resolution	5MP	
3	Image Format	2/3"	
4	Image Circle	φ11.0mm(MAX)	
5	EFL	3.5mm	
6	TTL	72.7mm	
7	F/NO.	1.4	
8	FFL (M)	12.4mm	
9	BFL (O)	17.53mm	
10	For Sensor	---	
11	F.O.V (D)	Ø11.0	152°
12		Ø8.0	110°
13		Ø6.0	84°
14	TV Distortion	<-37%	
15	Relative Ill.	>80%	
16	Chief Ray Angle	<20°	
17	M.O.D	0.1m~∞	
18	Mount Type	C/CS	
19	Dimension Figure	φ59.0*L60.3mm	
20	Lens Structure	All Glass	
21	IR-Filter	Non IR	
22	Weight	200g	
23	Iris Operation	Manual	
24	Zoom Operation	Fixed	
25	Focus Operation	Manual	
26	Operating Temperature	-20° ~+85°	
27	Storage Temperature	-20° ~+85°	

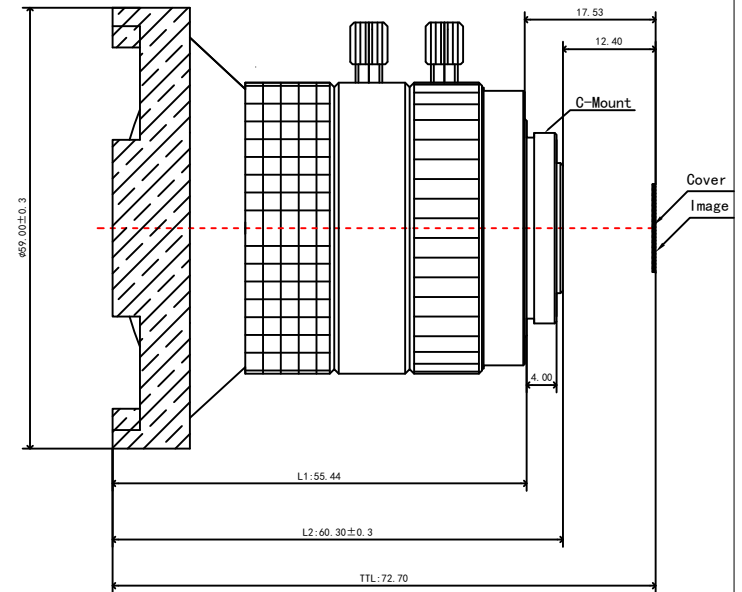

Scale	Remark	Tolerances	Date	Revised	
1 : 1	X	± 0.2	2019-06-14	CH3580A Rev1.0	
	X.0	± 0.15			
Units	X.00	± 0.10	Design	Linda	2018-03-11
	X.000	± 0.001	Checked	Anna	2016-04-12
mm	Angle	± 0.5°	Approval	Sanmu	2018-06-12

福州创安光电科技有限公司
FUZHOU CHUANGAN OPTICS CO., LTD

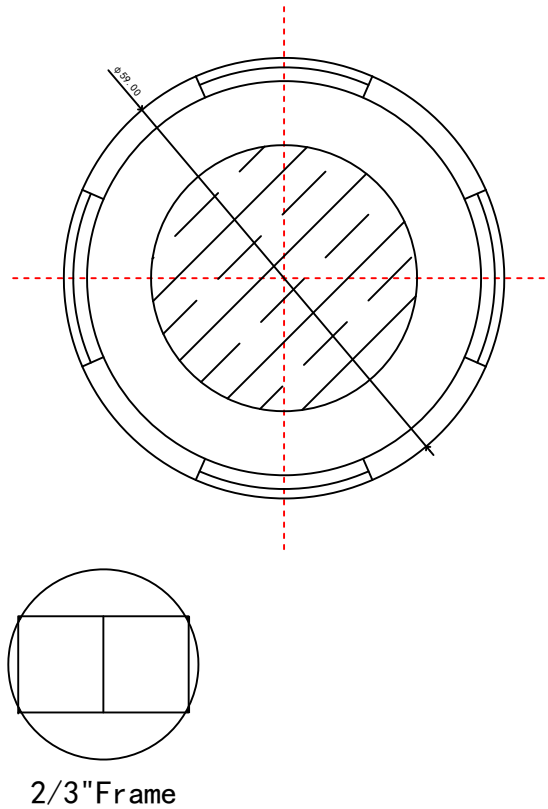
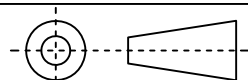

3D Angle Projection