

1	Type	Wide Angle Lens	
2	Resolution	MP	
3	Image Format	1/4"	
4	Image Circle	φ4.6mm(MAX)	
5	EFL	1.96mm	
6	TTL	24.76mm	
7	F/NO.	2.0	
8	FFL (M)	3.85mm	
9	BFL (O)	4.35mm	
10	For Sensor	1/4"	AR0140
11	F.O.V	Horizontal	130°
12		Vertical	90°
13		Diagonal	179°
14	TV Distortion	<30.3%	<28.33%
15	Relative Ill.	>70%	>69%
16	Chief Ray Angle	<23°	<20°
17	M.O.D	0.1m~∞	
18	Mount Type	M12*P0.5	
19	Dimension Figure	φ17.00*L20.91mm	
20	Lens Structure	6G6E	
21	IR-Filter	T=50% & 650±10nm	
22	Waterproof	No	
23	Weight	7.1g	
24	Iris Operation	Fixed	
25	Zoom Operation	Fixed	
26	Focus Operation	Manual	
27	Operating Temperature	-20° ~+85°	
28	Storage Temperature	-20° ~+85°	

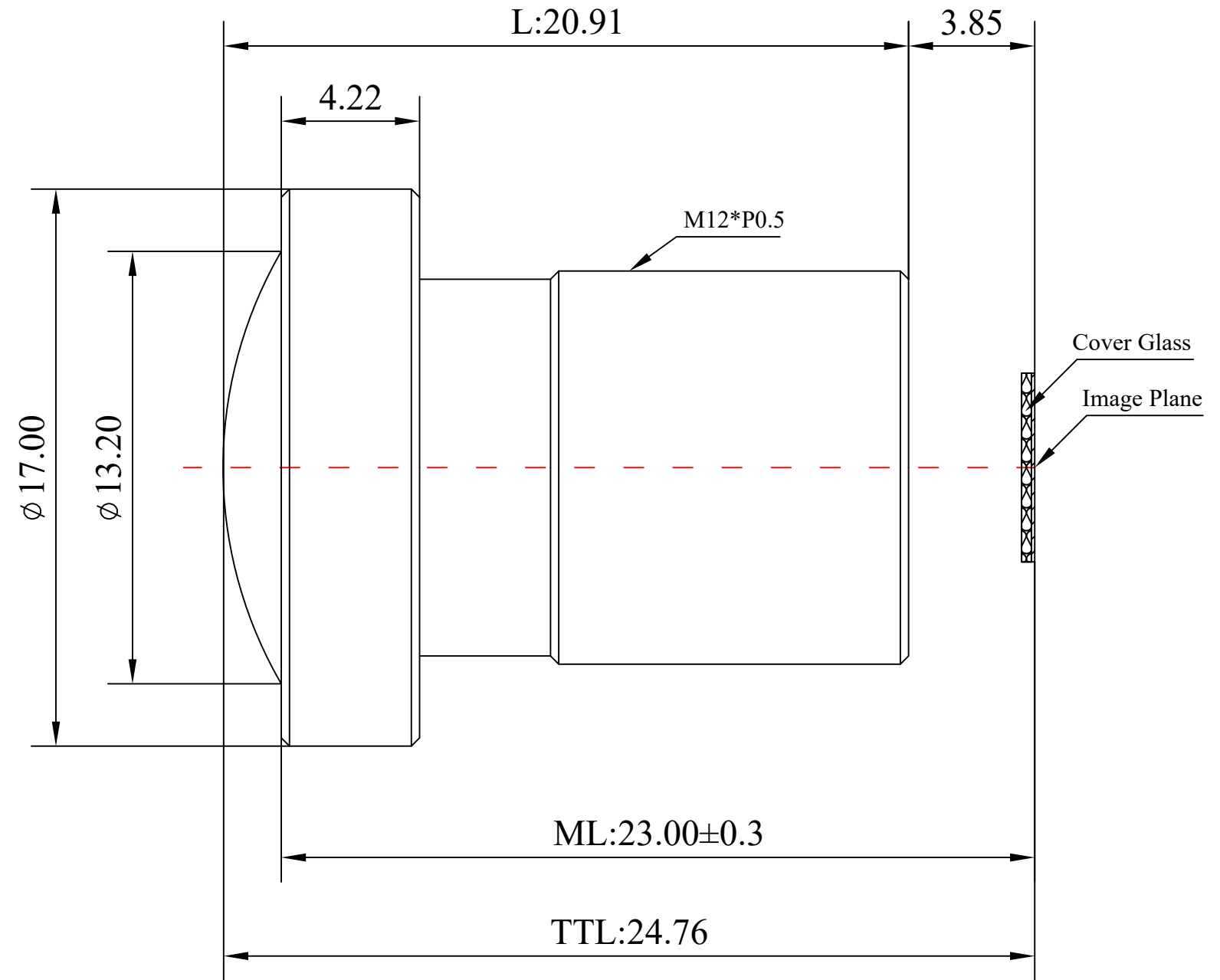

Scale	Remark	Tolerances	Date	Revised		福州创安光电科技有限公司 FUZHOU CHUANGAN OPTICS CO., LTD
4:1	X	±0.2	2019-08-16	CH3548BB Rev1.0		
	X.0	±0.15				
Units	X.00	±0.10	Design	Linda	2018-03-26	
	X.000	±0.001	Checked	Anna	2018-05-20	
mm	Angle	±0.5°	Approval	Sanmu	2018-05-20	

