

1	Type	Pinhole Lens
2	Resolution	MP
3	Image Format	1/3"
4	Image Circle	φ6.0mm(MAX)
5	EFL	12mm
6	TTL	25.50mm
7	F/NO.	1.6
8	FFL (M)	4.03mm
9	BFL (O)	7.70mm
10	For Sensor	1/3"
11	F.O.V	16.8°
12		
13		
14	TV Distortion	<-5%
15	Relative Ill.	>65%
16	Chief Ray Angle	<15°
17	M.O.D	0.1m~∞
18	Mount Type	M12*P0.5-6g
19	Dimension Figure	Ø12*L21.47mm
20	Lens Structure	4G
21	IR-Filter	Non IR
22	Weight	5.7g
23	Iris Operation	Fixed
24	Zoom Operation	Fixed
25	Focus Operation	Manual
26	Operating Temperature	-20° ~+45°
27	Storage Temperature	-20° ~+85°

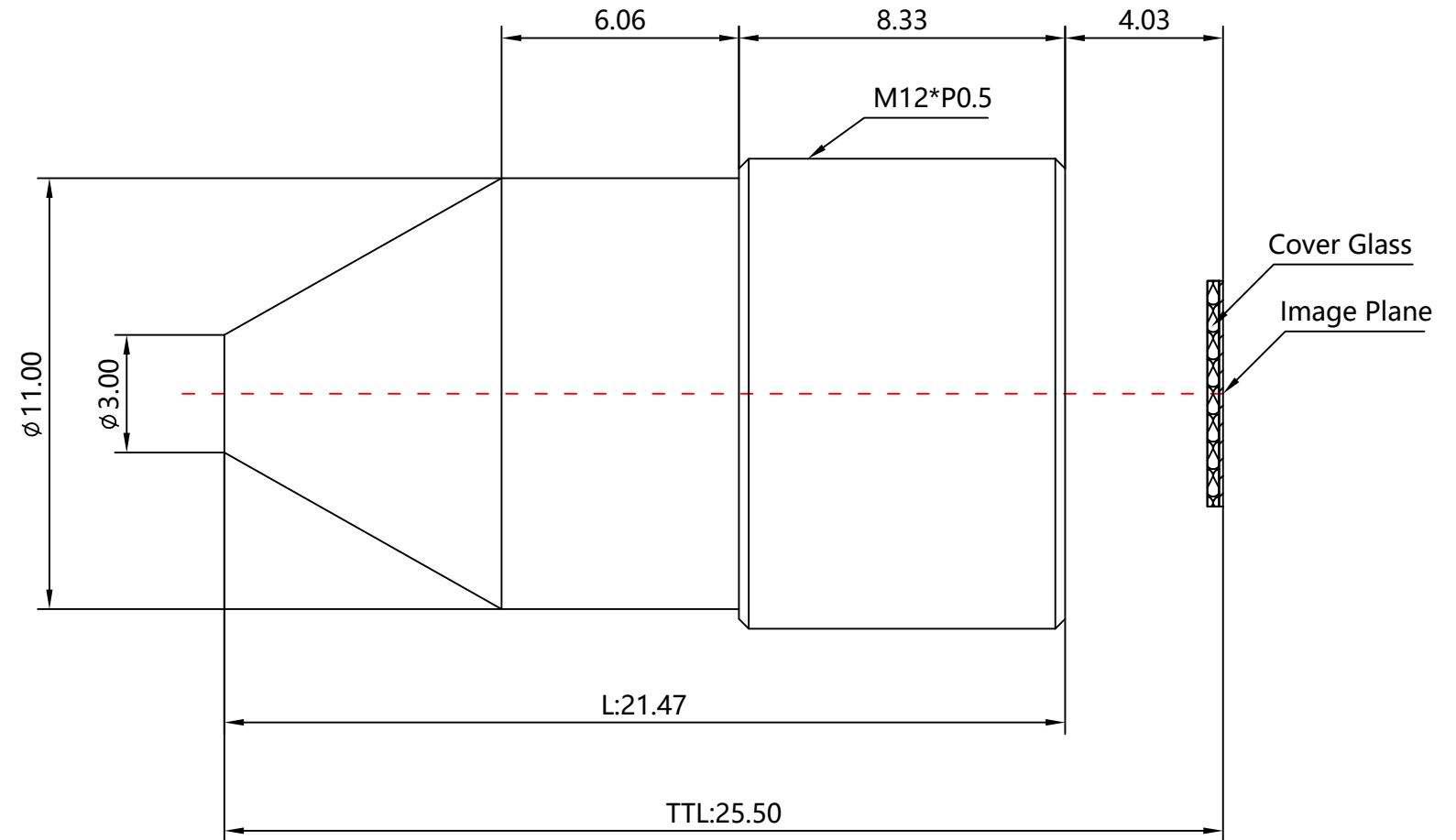

Scale	Remark	Tolerances	Date	Revised		福州创安光电科技有限公司 FUZHOU CHUANGAN OPTICS CO., LTD
4:1	X	± 0.2	2019-06-23	CH3306A Rev1.0		
	X.0	± 0.15				
Units	X.00	± 0.10	Design	Linda	2017-03-17	
	X.000	± 0.001	Checked	Anna	2017-04-26	
mm	Angle	± 0.5°	Approval	Sanmu	2017-06-15	

