

| | | | |
|----|-----------------------|-----------------|------|
| 1 | Type | Fisheye Lens | |
| 2 | Resolution | 16MP | |
| 3 | Image Format | 1/2" | |
| 4 | Image Circle | φ4.5mm(MAX) | |
| 5 | EFL | 1.2mm | |
| 6 | TTL | 28.68mm | |
| 7 | F/NO. | F2.4 | |
| 8 | FFL (M) | 2.00mm | |
| 9 | BFL (O) | 2.40mm | |
| 10 | For Sensor | 1/2" | |
| 11 | F.O.V | Horizontal | 230° |
| 12 | | Vertical | 230° |
| 13 | | Diagonal | 230° |
| 14 | TV Distortion | --- | |
| 15 | Relative Ill. | >90% | |
| 16 | Chief Ray Angle | --- | |
| 17 | M.O.D | 0.01m~∞ | |
| 18 | Mount Type | M12*P0.5 | |
| 19 | Dimension Figure | φ33.80*L28.68mm | |
| 20 | Lens Structure | 10G | |
| 21 | IR-Filter | Non-IR | |
| 22 | Waterproof | No | |
| 23 | Weight | 22.3g | |
| 24 | Iris Operation | Fixed | |
| 25 | Zoom Operation | Fixed | |
| 26 | Focus Operation | Manual | |
| 27 | Operating Temperature | -25° ~+85° | |
| 28 | Storage Temperature | -25° ~+85° | |

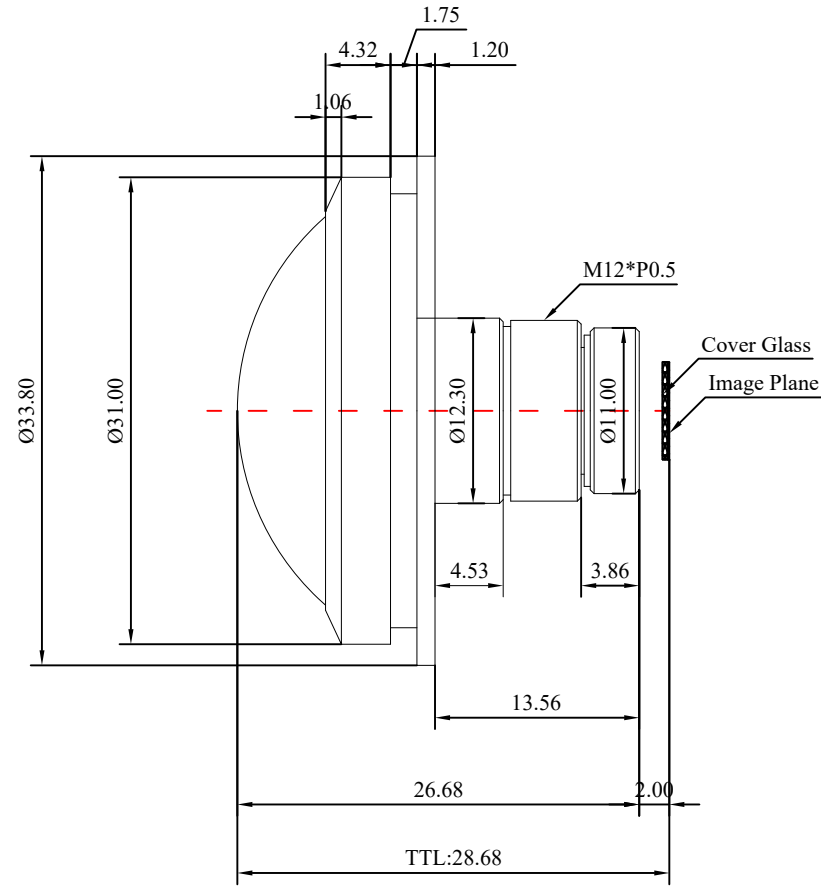
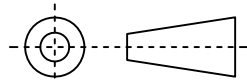

| Scale | Remark | Tolerances | Date | Revised | | 福州创安光电科技有限公司 FUZHOU CHUANGAN OPTICS CO., LTD |
|-------|--------|------------|------------|---------------|------------|--|
| 4:1 | X | ±0.2 | 2024-04-07 | CH300A Rev1.0 | | |
| Units | X.00 | ±0.10 | Design | Linda | 2024-02-27 |  3D Angle Projection |
| | X.000 | ±0.001 | Checked | Anna | 2024-03-11 | |
| mm | Angle | ±0.5° | Approval | Sanmu | 2024-03-17 | |