

1	Type	Wide Angle Lens			
2	Resolution	5MP			
3	Image Format	1/2.7"			
4	Image Circle	φ6.8mm(MAX)			
5	EFL	2.92mm			
6	TTL	13.97mm			
7	F/NO.	2.4			
8	FFL (M)	3.64mm			
9	BFL (O)	5.26mm			
10	For Sensor	OV2710	OV4689	OV5640	
11	F.O.V	Horizontal	132°	114°	85°
12		Vertical	66°	71°	62°
13		Diagonal	163°	146°	114°
14	TV Distortion	<-24%			
15	Relative Ill.	>63%			
16	Chief Ray Angle	<11°			
17	M.O.D	0.1m~∞			
18	Mount Type	M7*P0.35			
19	Dimension Figure	φ10.0*L10.33mm			
20	Lens Structure	5G			
21	IR-Filter	Non-IR			
22	Waterproof	No			
23	Weight	1.2g			
24	Iris Operation	Fixed			
25	Zoom Operation	Fixed			
26	Focus Operation	Manual			
27	Operating Temperature	-20° ~+85°			
28	Storage Temperature	-20° ~+85°			

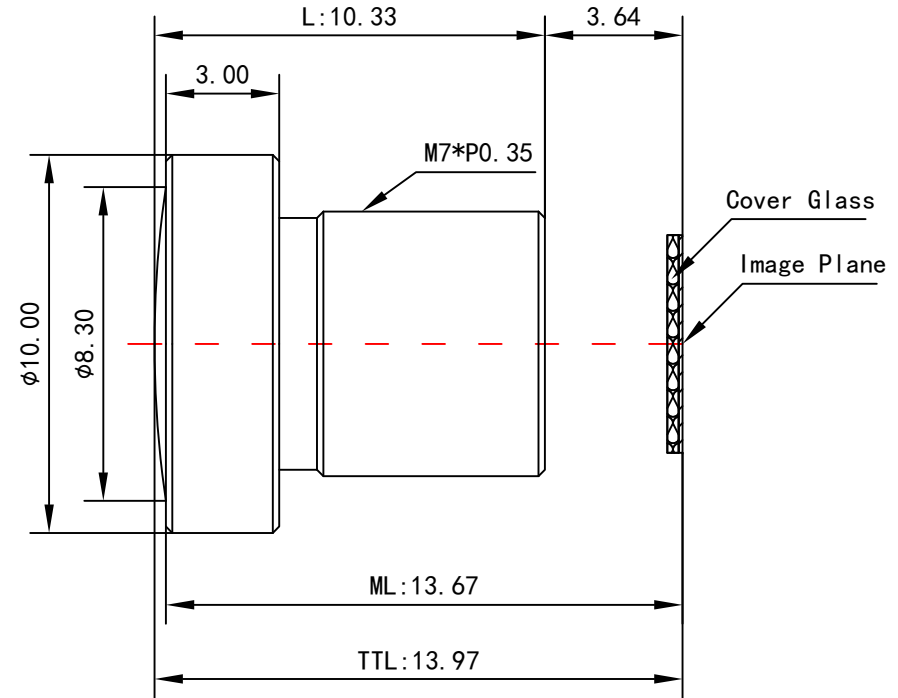

Scale	Remark	Tolerances	Date	Revised		福州创安光电科技有限公司 FUZHOU CHUANGAN OPTICS CO., LTD
5 : 1	X	±0.2	2019-05-07	CH1300i Rev1.2		
	X.0	±0.15				
Units	X.00	±0.10	Design	Linda	2016-06-15	
	X.000	±0.001	Checked	Anna	2016-08-05	
mm	Angle	±0.5°	Approval	Sanmu	2016-10-25	

